

Inspecting Square Socket Recesses

By Joe Greenslade

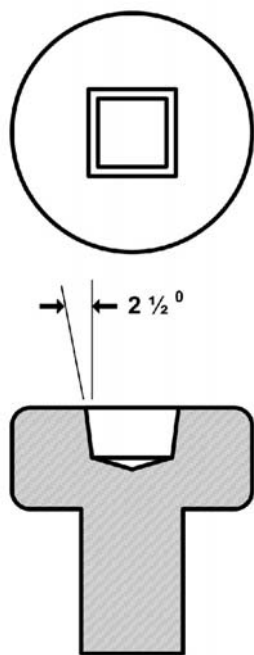

Square Socket Recess
ASME Type III

The use of square socket recessed screws has grown tremendously in recent years. The greatest growth has been in various types of screws used in the construction industry. The primary attraction of the square socket recess in these types of fasteners is its rigid fit on the driver bit which provides excellent driving control. This rigid fit is particularly beneficial in fasteners that are not driven into any type of pilot holes such as self drilling screws and deck screws.

The square socket recess was originally patented by the P.L. Robertson Company in Canada. Many people still refer to the square socket recess as the "Robertson Drive". Long after the patents

expired, the Industrial Fastener Institute (IFI) designated the square socket recess as the Type III recess. The American Society of Mechanical Engineers (ASME) added the square recess socket to the inch and metric machines screw and tapping screw standards (ASME B18.6.3, ASME B18.6.4, and ASME B18.6.M) in the 1990s.

Unfortunately, the original square socket standard published in the IFI 6th Edition Standards Book (Green Book) had one major technical error. That error was the designation of the wrong recess taper angle. The erroneous angle was shown as 1 1/2 degrees per side. **The correct recess taper angle is 2 1/2 degrees per side as shown above.**

This error was corrected by the time the square socket recess was incorporated into the ASME standards. Unfortunately, there are punch and screw manufacturers still making products with the incorrect recess taper. This has caused tremendous assembly problems in several USA OEM plants in recent years.

None of the IFI or ASME standards cover proper gaging design and usage adequately. The original IFI standard had a completely incorrect penetration gage design and no fit or wobble gage. The ASME standards have the correct penetration gage design and they show a fit gage, but some important details, including gage usage, are still not covered.

The proper and thorough gaging of square socket recesses includes the three following inspections:

1. Penetration
2. Fit
3. Wobble

□ Penetration Gaging

The correct square recess penetration gage consists of a square penetration point which slides inside a gage body that is connected to a dial or preferably a digital indicator. If a dial indicator is used in this gage, the indicator must be one that reads in reverse. This means that as the stem of the indicator is pressed into the indicator, the dial value must get smaller and not larger, which is the case in most dial indicators. This issue is generally not a concern when using digital indicators because they can read in either direction by simply making the correct setting selection.

The square across-flats dimension is equal to the smallest dimension on the tapered fit and wobble gage referred to in the standards as the "A" dimension. The face of the gage body is flat and smooth. It does not have the raised ridges that are standard on Phillips penetration gages.

To prepare the penetration gage for use, the face of the penetration gage is pressed against a flat

surface to depress the penetration point into the gage body and then the indicator is set to zero. The gage is then lifted, allowing the square penetration point to extend beyond the face of the gage body.

The screw's recess is then placed firmly on to the penetration point. The screw is then pressed toward the face of the gage body until contact is made between the screw's top surface and the face of the gage body. The value showing on the indicator is the penetration measurement of the screw's recess.

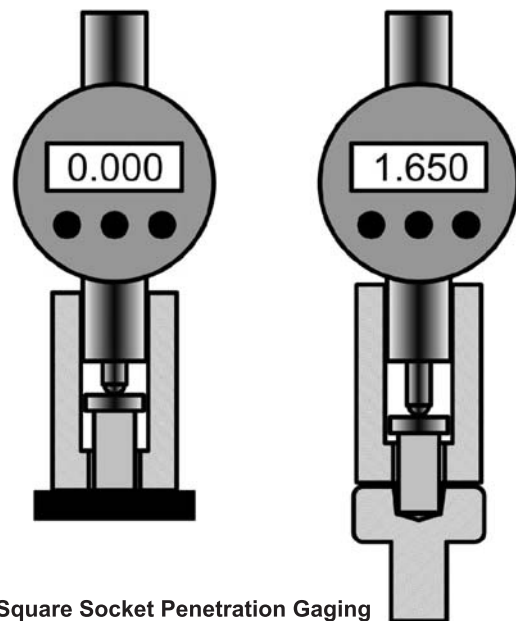

Square Socket Penetration Gaging

□ Fit Gaging

The same gage point is used to inspect for recess fit and angle as well as wobble. The critical detail that the current ASME and IFI standards do not contain is the location of the "acceptance lines" on the tapered gaging point.

The error described above in the recess taper

angle is readily visible when the fit/wobble point is inserted into the screw recess. When the fit plug is inserted into the screw's head the top of the head should lie between the two "acceptance lines". If the top of the screw's head falls between the two acceptance lines, the recess has the proper recess taper angle.

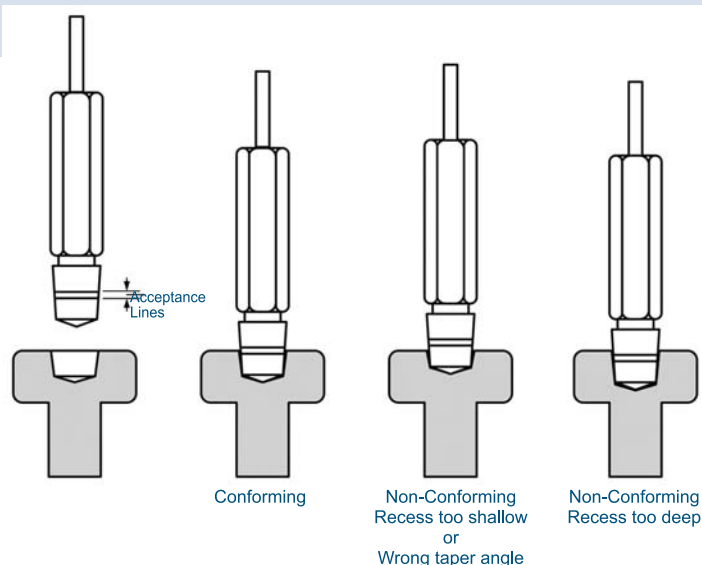

A good square socket recess will cling to the fit gage. To inspect for "cling", press the screw on to the gage point while holding both horizontally and without holding the screw on to the gage, turn the gage horizontally with the point of the gage pointing downward. The fit is acceptable if the screw clings or sticks on the gaging point.

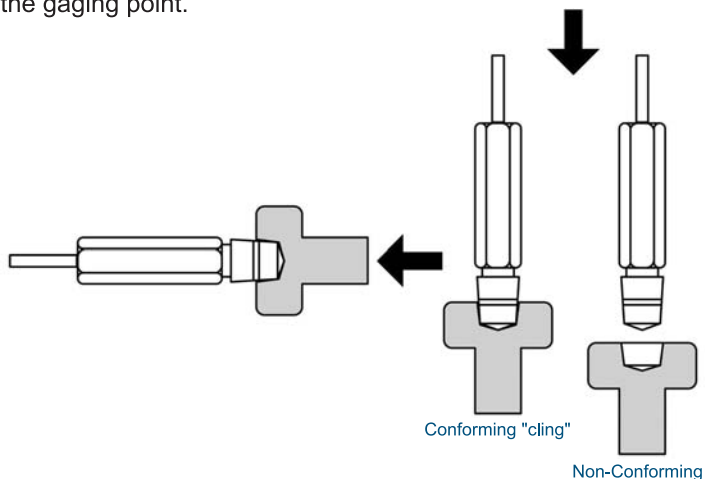

Wobble Gaging

If the fit gage has the wobble pointer on the end of the gage opposite the square fit point, it can be used to measure recess wobble. The procedure for measuring the wobble in a square recess socket screw is as follows:

1. Place the screw in the chuck of the wobble fixture and tighten the chuck on the screw's body.
2. Insert the square end of the wobble plug into the screw's recess. Adjust the location of the chuck in the fixture so the end of the plug opposite the square is level with the top of the wobble fixture. Rotate the chuck so the "+" on the end of the plug lines up with the degree marks on the top of the wobble fixture. Lock the chuck into place.
3. Slightly press on each side of the gage plug. Note the number of degrees of movement as indicated by the position of the "+" on the end of the plug to the degree marks on the top of the fixture.
4. Rotate the chuck 90 degrees and press the plug side to side again and note the movement.

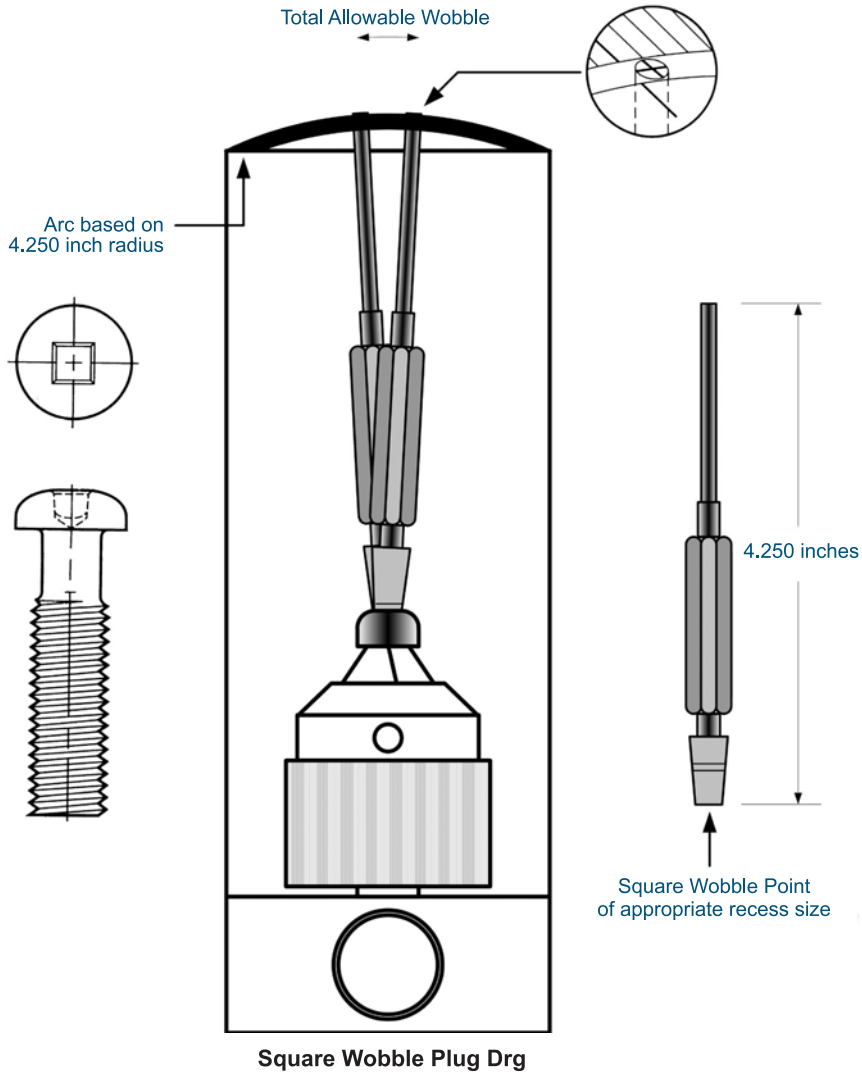

Square Wobble Plug Drg

To be acceptable the wobble plug must not exceed the values as shown below:

Gaging Limits for Type III Recesses

Recess Size	Maximum Allowable Total Wobble in Degrees
00	6
0	6
1	5
2	4
3	4
4	3

Only after doing all three of these inspections (penetration, fit, and wobble) can a square socket recess be determined to be acceptable. If a screw does not meet all three requirements, the end user will probably encounter screw driving problems when installing the screws.

For more information on this and other fastener testing and inspection questions contact the author at sales@greensladeandcompany.com.

